

Technology Proven also at Highly Dynamic Aerobatic Flights during Red Bull AirRace 2016

# **iNAT: INS/GNSS for Trainer Aircrafts, for UAV Control and for Precise Aircraft Trajectory Surveying**

**Edgar v. Hinüber<sup>1</sup>, Christian Reimer<sup>1</sup>, Tim Schneider<sup>1</sup>, Michael Stock<sup>2</sup>**

<sup>1</sup> iMAR Navigation GmbH, St. Ingbert / Germany

<sup>2</sup> Stock Flight Systems, Berg / Germany

## **1 ABSTRACT**

The paper presents the capability and performance of a light weight inertial measurement system to acquire all relevant flight dynamical measurements as they are present during high dynamic training flights, e.g. for jet trainers. The paper presents a new family of light weight low power INS/GNSS solutions based on MEMS sensors, being used for UAV navigation and control as well as for aircraft motion dynamics analysis and trajectory surveying. One key is an up to 42 state extended Kalman filter based powerful data fusion, which allows also the estimation and correction of parameters which are typically affected by sensor aging, especially when applying MEMS based inertial sensors. The paper presents the general system architecture, which allows iMAR Navigation the integration of all classes of inertial sensors and GNSS receivers from very-low-cost MEMS and high performance MEMS over FOG (fiber optical gyro) and RLG (ring laser gyro) up to HRG (hemispherical resonator gyro) technology, and presents detailed flight test results being obtained also under extreme flight conditions. As an impressive example of system performance even under challenging dynamics environment the aerobatic maneuvers of the World Champion 2016 (Red Bull Air Race) are presented. A short view is also given to surveying applications, where the ultimate performance of the same data fusion, but applied on iMAR's ring laser gyro systems, is discussed.

**Keywords:** advanced inertial navigation; trainer aircraft; jet pilot education; INS/GNSS; data fusion; aerobatic flight; fighter aircraft; MEMS IMU; gyro; high dynamics UAV control

## **2 INTRODUCTION**

iMAR Navigation GmbH, located in St. Ingbert in the southwestern of Germany, is known as a designer and manufacturer of precise and reliable inertial measurement systems for navigation, surveying and control since now more than 20 years. Due to the deep knowledge about inertial technology regarding all kinds of gyro technology from MEMS over FOG and RLG up to HRG, data fusion and system integration, combined with the capability and certification also to manufacture safety relevant systems, iMAR Navigation is a leading and worldwide operating provider of standard and customized inertial measurement and tracking solutions.

iMAR operates extensive in-house facilities including electronics and mechatronics integration labs, CNC machine tools, several turntables, a vibration & shock testing machine, temperature chambers, a hexapod

motion simulator for up to 1 ton payload or a 3 axes precise coordinate measurement machine for quality assurance of in-house and external manufactured mechanical components. This equipment, as a base together with the strong skills of our more than 60 highly experienced engineers, scientists, technicians and administrations, guarantee the success of our systems and solutions in the market of industrial, automotive and defense applications on the ground, on the sea and in the air.

With iNAT-M200/SLN this paper presents a system being a brilliant choice to monitor dynamics and trajectory e.g. of trainer aircrafts as well as the technology behind the successful iNAT systems. As an example, flights performed during Red Bull Air Race 2016 (Figure 1) in Ascot / UK and at Lausitzring / Germany in the Master's Class are shown and also compared with results of a competing system. For that the iNAT-M200/SLN had been mounted on the aerobatic aircraft of Matthias Dolderer, the German's participant in the Master's League and the World Champion 2016. These flights are very interesting because they show the most challenging demands of aerobatic flight conditions for an inertial navigation system, which cover also all flight maneuvers usually flown by fighter pilots during their training flights.



Figure 1: Red Bull Air Race

### 3 SYSTEM ARCHITECTURE - HARDWARE

All iNAT systems feature a similar hardware architecture which differs only in the used inertial sensors, the data acquisition setup and the variety of data output interfaces. This means, that the embedded computing, calibration, signal processing and output protocol modules stay the same throughout the entire product lineup.

The iNAT-M200 INS/GNSS system, which is used to acquire the measurement results being discussed in the following chapters, is designed for navigation, localization and attitude / heading measurement as well as for performing control tasks of manned and unmanned



Figure 2: iNAT-M200/SLN (INS/GNSS based inertial navigation, surveying and control system)

vehicles like UAVs (unmanned air vehicles), AUVs (autonomous underwater vehicles), UGVs (unmanned ground vehicles) or UMVs (unmanned marine vehicles). With its 750 grams and 8 W power consumption the iNAT-M200/SLN (see **Figure 2**) is a real light weight and low power



Figure 3: iNAT-RQT based on ring laser technology

system, which is nevertheless equipped with an integrated high grade MEMS based inertial sensor assembly (several classes of performance available), an integrated GNSS receiver (up to L1L2 GPS+GLONASS+GALILEO & RTK), an integrated wheel sensor (odometer) interface (A/B RS422 level), an integrated powerful miniaturized strapdown computer with data fusion (42 state Kalman filtering) and which provides all commonly desired interfaces (Ethernet, UART RS422/RS232, CAN, USB, SYNC) to communicate with external systems. The iNAT-M200 supports all usual data protocols like TCP/IP, UDP, NMEA 0183, CANaero, ARINC825 and many others as well as customized communication layers. ARINC429 is additionally available on the systems of type iNAT-RQT, iNAT-RQH, iNAT-FSSG, iNAT-FSLG and iNAT-HQS, which cover all sensor technologies from MEMS over fiber optic gyros, hemispherical gyros up to highest performance ring laser gyros.

The **Figure 3** shows the iNAT-RQT-4003, a compact high performance class INS/GNSS system with ring laser gyroscopes and with gyro compassing capability, as it is e.g. used by Airbus Helicopters (Eurocopter) as master flight reference system since 2016. It is e.g. used to survey the aircraft's trajectory during performing standard and extended flight tests and aircraft approvals.

**Figure 4** shows the block diagram of the iNAT-M200 system. The achieved high system performance is a result of the high performance of the used inertial sensors, the good performance of the used GNSS engine, the high sophisticated strapdown and data fusion algorithms and the excellent time synchronization inside the mixed FPGA/μC architecture.

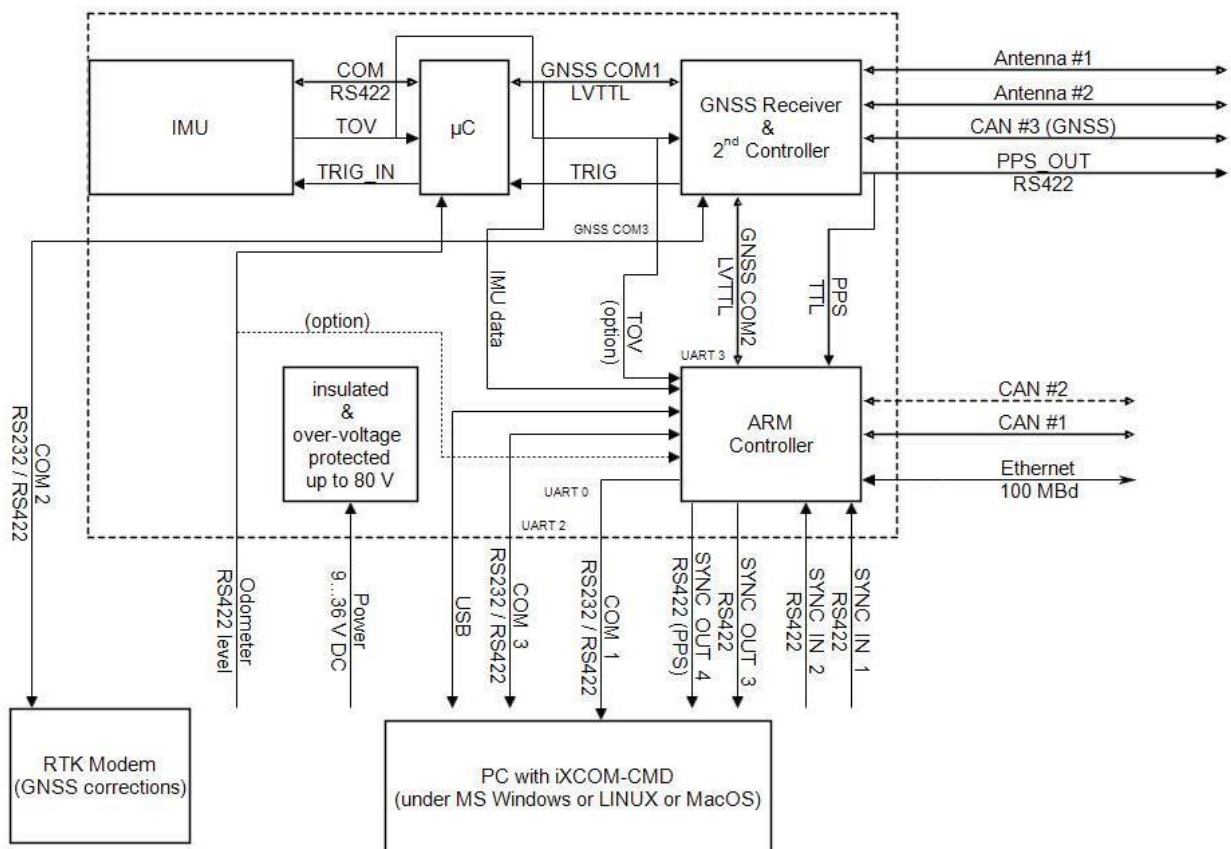

Figure 4: iNAT-M200 Block Diagram

Detailed information about the iNAT systems can be found on [www.imar-navigation.de](http://www.imar-navigation.de).

## 4 SYSTEM ARCHITECTURE - SOFTWARE

All iNAT systems feature a common firmware which differs only in the sensor-readout module while the calibration, signal processing and output protocol modules stay the same throughout the product lineup. This ensures complete behavioral compatibility between different device classes, allowing customers to easily switch between INS performance classes without even touching their interfacing software.

The software module architecture is depicted in **Figure 5**, where the software itself is operated on a real-time operating system. After sampling the inertial sensors, sensor and system-level compensation algorithms are performed on their outputs. The compensated data are then used to drive the strapdown and Kalman filter algorithms to produce an optimal INS/GNSS solution. The output module produces outputs for different protocols, which may be output over the available hardware interfaces. Supported protocols for output over Ethernet, UART or USB are the iMAR proprietary iXCOM protocol, as well as NMEA 0183. The CAN bus supports either ARINC 825 or CANaero. Furthermore, ARINC 429 is supported depending on the hardware configuration. The output rate of messages in either format is adjustable to integer divisors of the inertial data rate and the output sequence as well as the data composition of the messages is adjustable for ARINC 429.

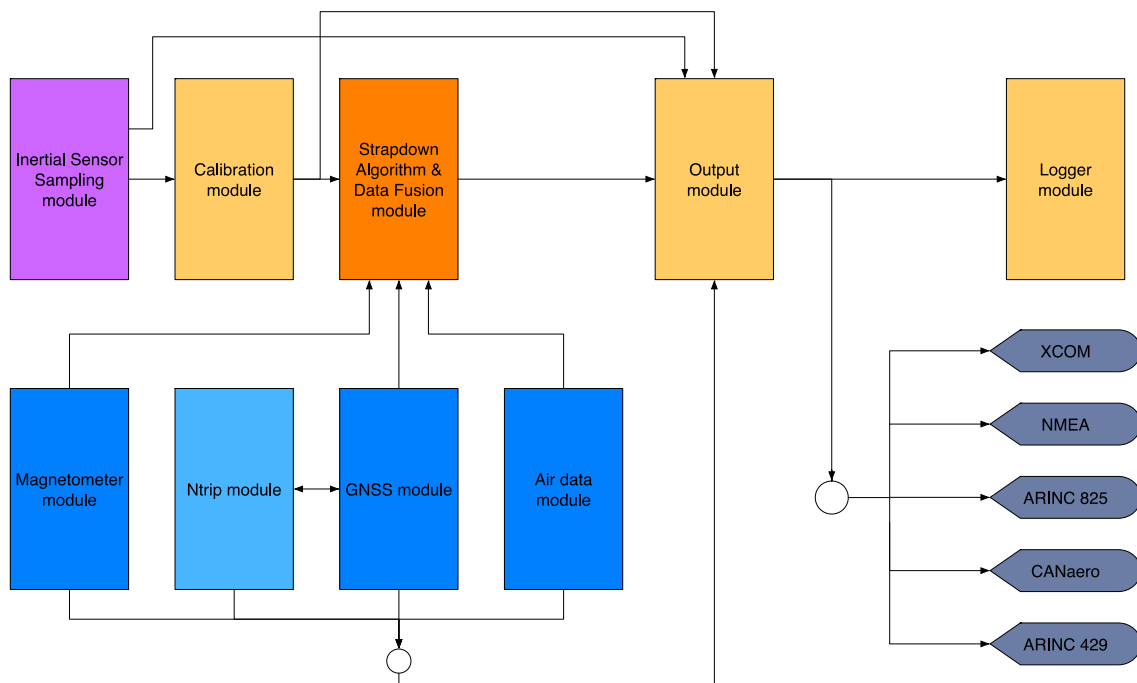

Figure 5: iNAT software module architecture (excerpt)

The modular software architecture enables iMAR to develop customer-specific applications running on the IMS (*inertial measurement system*, here used as a generalization of INS, which means only *inertial navigation system*) itself which may be used to convert from a customer-specific protocol to iXCOM and back (see **Figure 6**), easing the development of form, fit & function replacement of legacy hardware with an iNAT IMS.

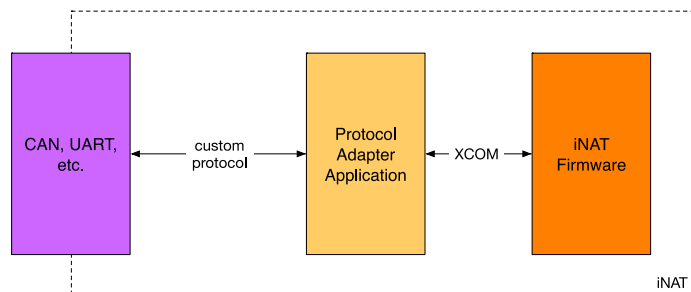

Figure 6: Realization of custom protocols on iNAT systems



Another integral part of the iNAT series is the embedded data recorder functionality. This feature is also useful to monitor the trajectory and dynamic behaviour of trainer aircraft to allow an effective education of the pilot also in post mission.

All iNAT systems employ an SD card with storage capacities of 32 GByte. The data recorder may be set up to log timestamped raw inertial data at the full IMS data rate as well as GNSS raw data for post-processing, as well as all other logs available in the iXCOM protocol. Furthermore, logging of CAN traffic and correction data received via the integrated NTRIP client may be enabled. All logged data can be retrieved from the system through an FTP connection.



Figure 7: iXCOM-CMD Graphical User Interface (GUI)

For system configuration and data visualization, iMAR offers the iXCOM-CMD GUI software for MS Windows™, Linux and MacOS (Figure 7).

This software communicates with the iNAT device over the iXCOM protocol and may also be used to download data from the integrated SD card by the integrated FTP client. A great number of visualization options is available, including an artificial horizon, g-meters and speed gauges (Figure 9). The horizontal position can be visualized on an OpenStreetMap based powerful graphical moving map with both online and offline map support capability. **Figure 10** shows a screenshot of the qualification race of Red Bull Air Race in August 2016 in Ascot / UK, obtained with such an iNAT-M200 system, **Figure 8** shows the trajectory as horizontal and altitude plot, also within iXCOM-CMD.

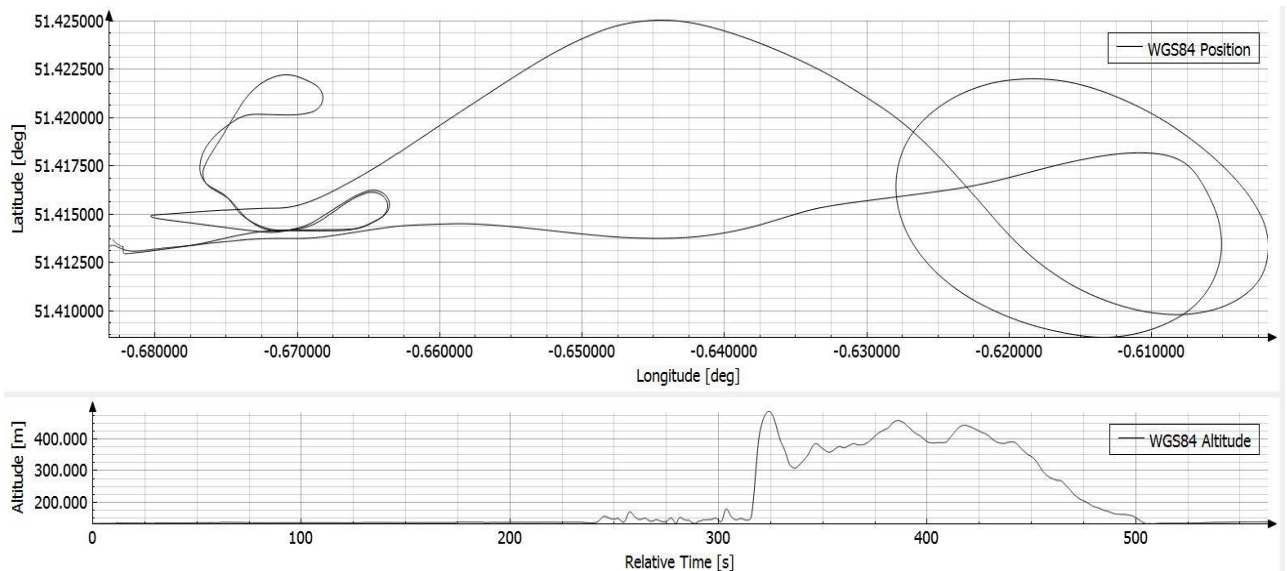

Figure 8: iXCOM-CMD generated plot of flight trajectory

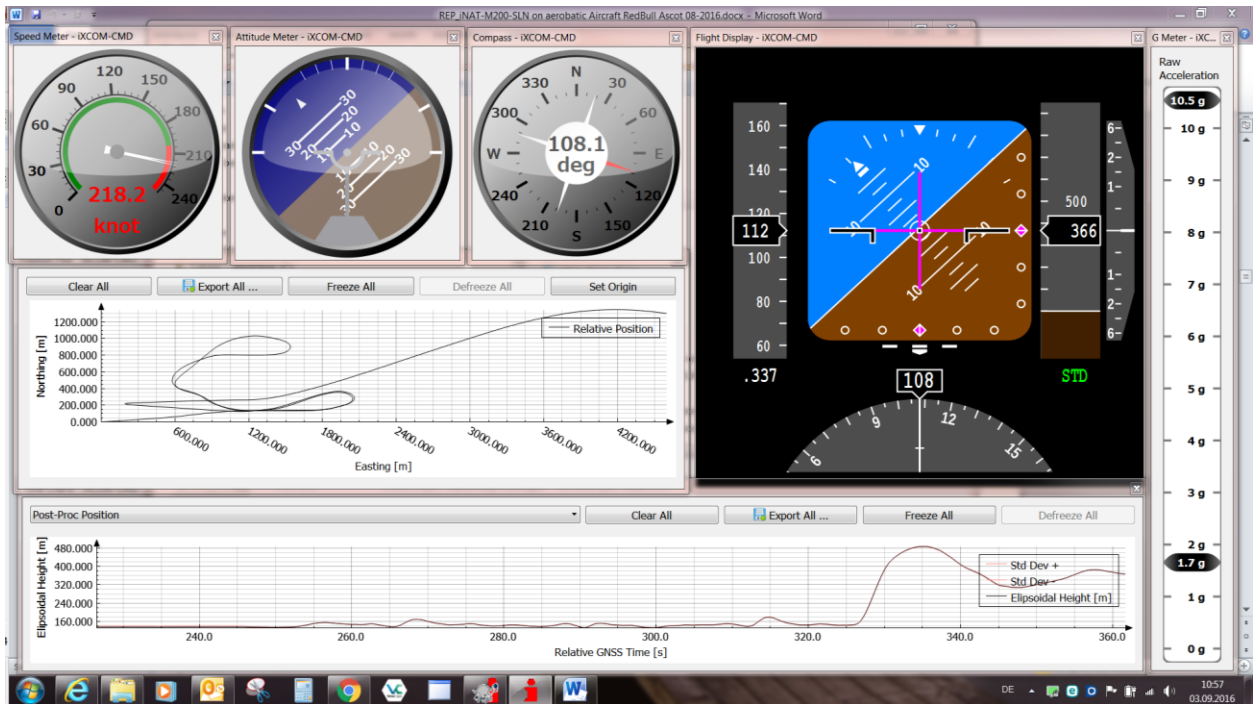

Figure 9: Graphical Instruments and Plots inside iXCOM-CMD (screens can be adjusted by user)

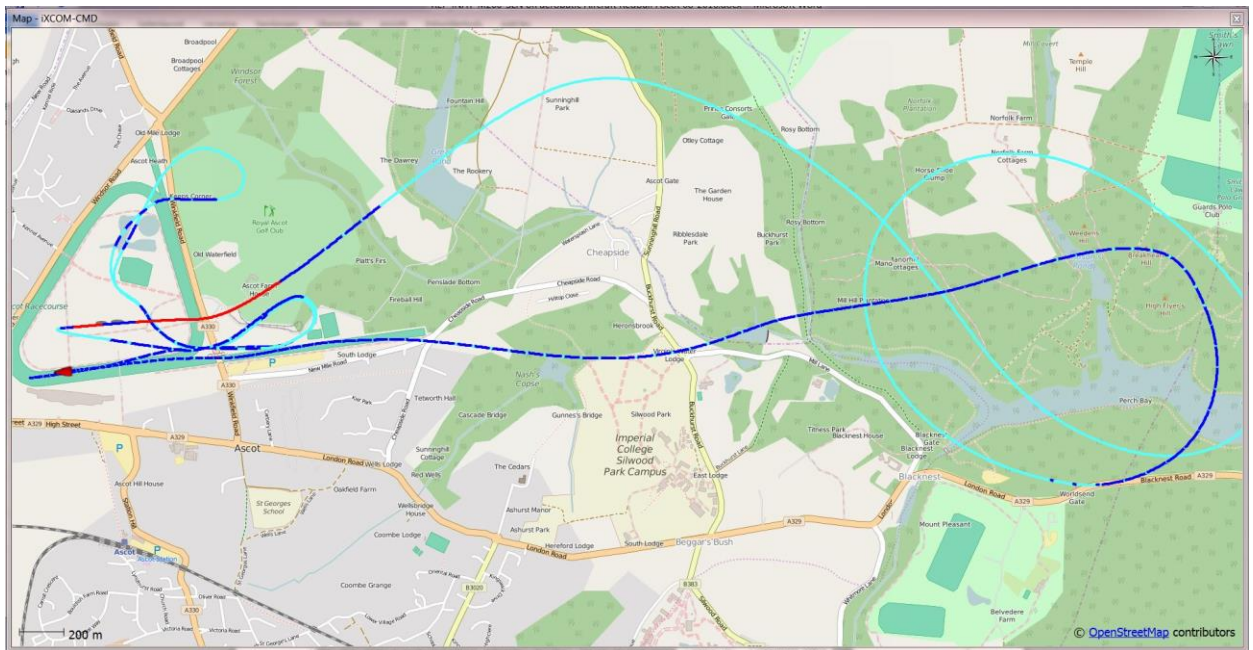

Figure 10: Moving Map of iXCOM-CMD incl. INS/GNSS status visualization to support rapid analysis

## 5 SYSTEM ARCHITECTURE – SIGNAL PROCESSING

After acquisition of the inertial data and compensating for mechanical misalignment and temperature-dependent errors, they are processed by the strapdown algorithm to propagate the INS solution. The strapdown algorithm uses an ECEF mechanization with a quaternion attitude representation, allowing polar operation and attitude propagation even under challenging aerobatic maneuvering.

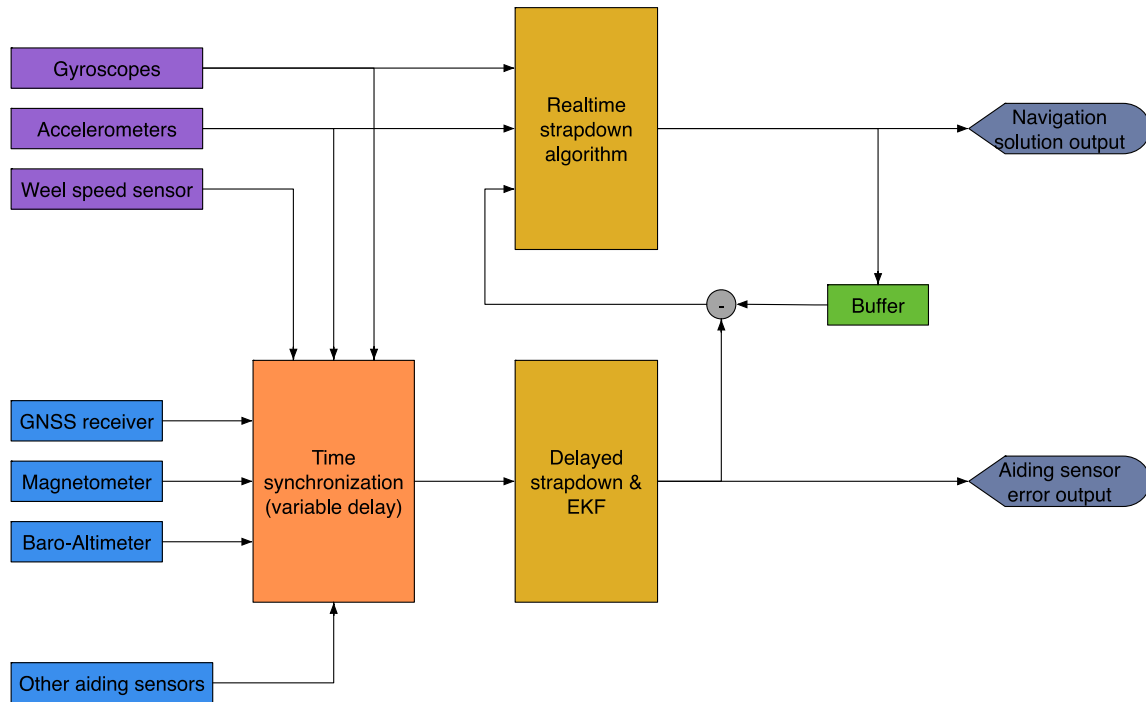

Figure 11: iNAT Signal Processing - Data Fusion

The outputs of the strapdown algorithm are then converted to the familiar curvilinear position and Eulerian angles. The inertial drift errors of the strapdown algorithm due to sensor errors are continuously corrected by the output of the Kalman filter module, which integrates - inside of a sophisticated and robust data fusion - measurements from different aiding sources like GNSS, magnetometer, air data or odometer to achieve an optimal solution.

**Figure 11** depicts the data flow between the realtime-strapdown algorithm and the Kalman filter module. The Kalman filter operates on buffered data because the availability of measurements is usually delayed with respect to their time of validity (e.g. up to 0.2 s between the PPS (pulse per second) hardware signal of the GNSS receiver and the GNSS solution output via UART for some receivers). All measurements are timestamped with better than 1  $\mu$ s accuracy and are assimilated in the EKF at their exact time of validity.

Depending on availability, in aviation applications the Kalman filter based data fusion makes use of measurements from the integrated GNSS engine, barometric altitude and airspeed measurements from a connected air data computer and magnetic field measurements. Because of the tightly coupled operation of the Kalman filter, an aiding with GNSS is possible even when less than four GNSS satellites are available. The Kalman filter also includes states to compensate for barometric offsets with respect to the GNSS-referenced height above ellipsoid. Calibration of the magnetometer soft and hard iron errors as well as misalignment between the IMS and the magnetometer is accomplished by an easy-to-use integrated calibration tool.

For the usage in trainer aircrafts, typically the information from barometer, true airspeed and magnetometer are not used inside the data fusion algorithm to obtain the flight trajectory. iMAR's strapdown algorithms and signal processing inside of the iNAT systems are so excellent, that those information is not required to achieve the best performance. And the benefit of iMAR's signal processing for trajectory determination is, that any natural or environmental distortion on the earth magnetic field vector or on the wind or on



barometric pressure have absolutely no impact on the measurements of aircraft position, speed, attitude, heading, side slip angle, angle of attack etc.

Each inertial measurement system has to be aligned to the coordinate system in which it shall provide its measurements. Typically, such an alignment is performed as a ground alignment at standstill, e.g. on the taxiway of the airport. The iNAT systems, however, employ additionally a sophisticated "In-Motion Alignment" routine which allow the system to be in-motion during the alignment. This algorithm does not impose any constraints on the type of motion during the alignment, thereby considerably decreasing the burden on the aircraft operator to keep track of the IMS state during initial ground operations and even allowing an in-flight realignment during dynamic maneuvering.

## 6 RESULTS OBTAINED ON AN AEROBATIC AIRCRAFT

iMAR has been partnering with the aerobatic pilot Matthias Dolderer (Germany) and Stock Flight Systems for trajectory optimization in the Red Bull Air Race since its reconception in 2014.

The Red Bull Air Race, established in 2003 and created by Red Bull GmbH, is an international series of air races in which competitors have to navigate a challenging obstacle course in the fastest time. Pilots fly individually against the clock and have to complete tight turns through a slalom course consisting of pylons, known as "Air Gates". During this course, turn rates reaching up to 400 °/s and load factors of up to 10g and even more act on the plane and on the pilots.

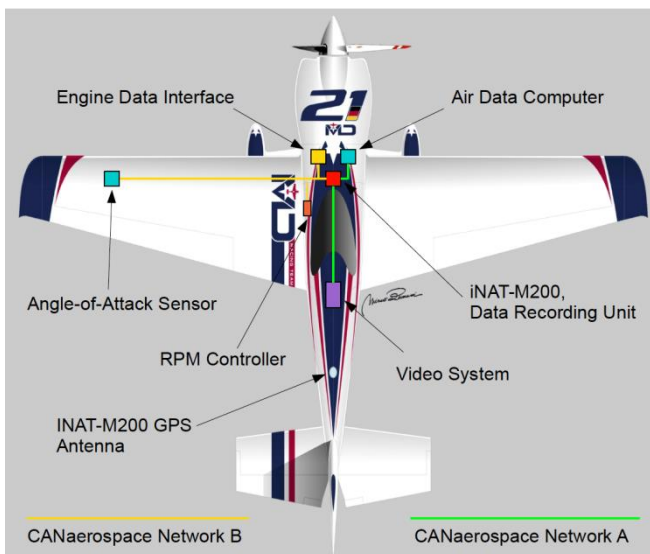

Figure 12: Setup of Measurement Systems on the race plane

Matthias Dolderer's team MD21 uses the CANaerospace Data Acquisition and Recording System (CDARS) from Stock Flight Systems, with the inertial navigation solution provided by an iMAR iNAT-M200/SLN. Together with numerous other measurement equipment, the CDARS installation in MD21's Zivko Edge 540 V3 RSR race plane provides unprecedented potential for optimization in flight trajectory, the flight dynamics and the coordination of pilot controls and engine management. All measurement and control units interact with each other using two 1 Mbit/s CANaerospace networks with a miniaturized and lightweight data logger recording all data synchronously.

This setup is very similar to the requirements for trainer aircrafts, e.g. for fighter pilot education, to monitor the pilot's actions and to provide these information both in real-time as well as in post-mission to allow the best feedback to the pilot and to enhance the success of the pilot's training.

**Figure 12** shows a block diagram of the most important measurement systems on such airplane. The logged data can be extracted and analyzed with a highly specialized software tool, which displays the flown trajectory and for every point on the trajectory the current kinematic state of the airplane (3D velocity and attitude, accelerations and angular rate, obtained from the iNAT-M200), as well as important flight parameters like true airspeed or engine RPM. This complete assessment of aircraft state enables MD21's race engineers and tacticians to identify crucial spots in the track, and thus enables shoving off split seconds from the time even in the very short breaks in-between subsequent runs of training, qualifying and the race.



Figure 13: iNAT-M200 in Race Plane



Figure 13 shows the integration of the iNAT-M200/SLN into the race aircraft at Tannheim Airport.

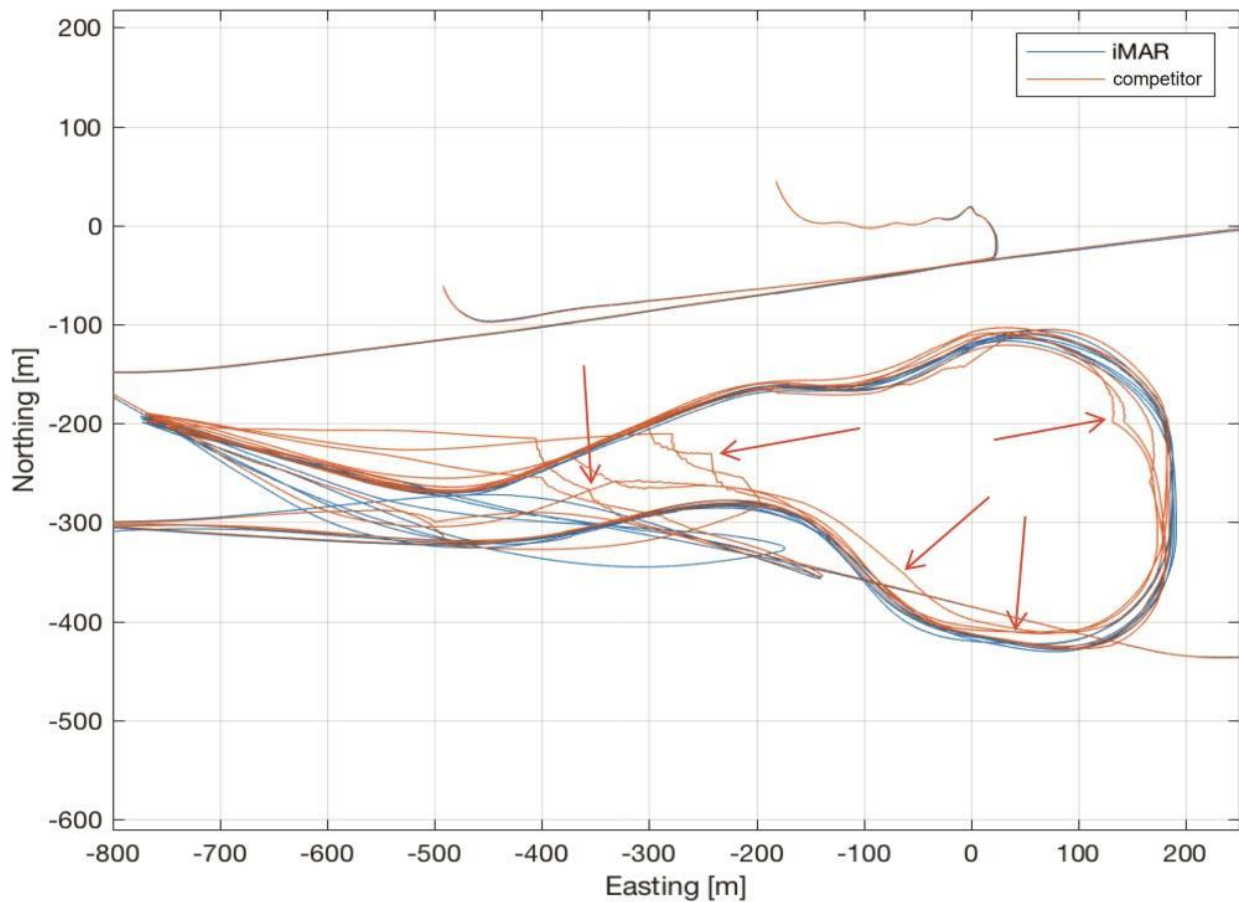

Figure 14: Comparison of Trajectory – iMAR Navigation vs. competitor's solution on the same aircraft (Lausitz)

Figure 14 shows the trajectory recorded by the iMAR iNAT-M200/SLN (IMS with single GNSS antenna solution) during the free training for the Air Race at Lausitzring on September 3rd-4th, 2016, together with the trajectory being recorded by a competitor's INS/GNSS device (from a manufacturer from Australia, who called its systems to be an "advanced" navigation solution). Both systems had been installed on the same MD21 race aircraft during all races, affirming by both manufacturers to provide the correct performance according to their experience.

Nevertheless, as shown over a long history of flights, only iMAR Navigation's iNAT-M200 provided all the time superior results, even under these extremely harsh conditions with several high-g turns (peaking at over 11g, see Figure 16) and prolonged GNSS outages of up to 15 seconds or even more during loops and barrel rolls.

While these conditions do not lead to any discontinuities in iMAR's navigation result, the competitor's product shows much bigger drift during these outage periods and several big correction impulses of their data fusion after the end of these outages (see red arrows in the plot), rendering any kind of detailed trajectory analysis impossible. Due to that, team MD21 relied entirely on the iMAR system for the Red Bull Air Race season 2016, which had probably been one of the important stones in the puzzle of optimization of aircraft and flight technique to led Matthias Dolderer taking the World Champion title one race even before the end of the season in October 2016.

Figure 15 shows attitude and heading during such flight. A roll angle of 180 deg or -180 deg indicates an inverse flight (upside down), where also the GNSS antenna was oriented to the ground (and hence no GNSS satellites are in view). The angular rates show the high dynamics, especially on the roll axis, which also leads to very high centripetal acceleration impacts, which must be well handled inside the strap down computation to avoid related deviations.

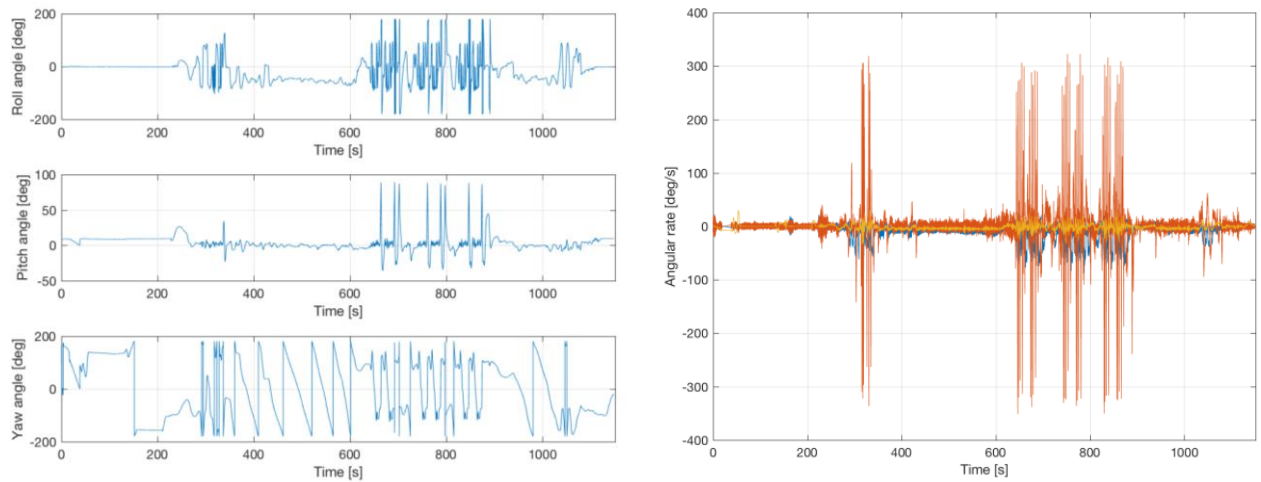

Figure 15: Roll, Pitch & Yaw and angular rates during aerobatic flight

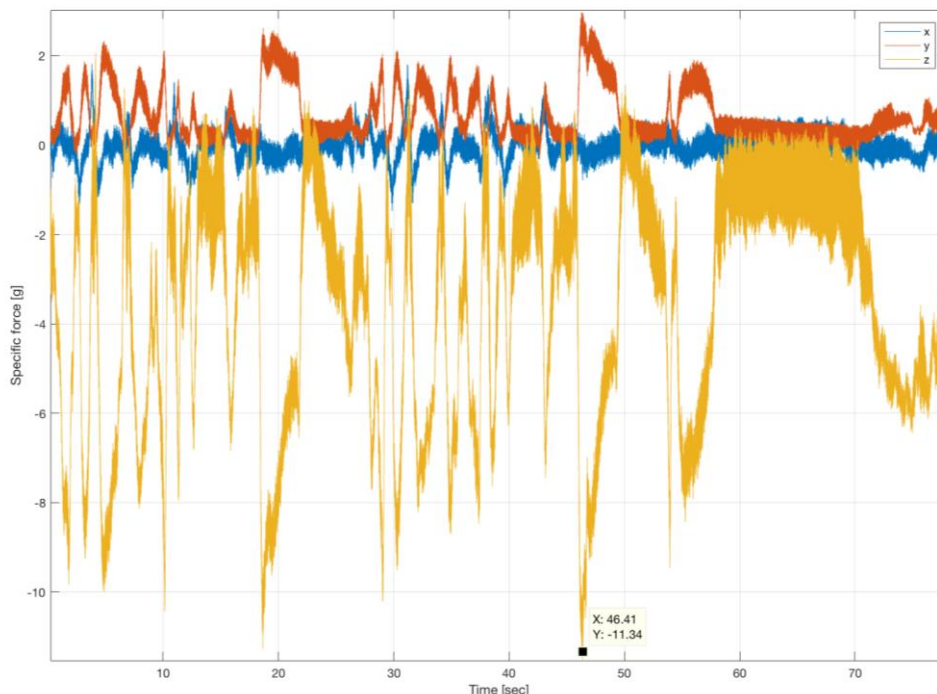

Figure 16: G-Forces experienced during a training flight at Red Bull Air Race

**Figure 17** shows similar results from the ASCOT race in August 2016. Here we see deviations of up to 50 meters and even more of the competing product.

Another important advantage of iMAR's iNAT-M200 over the competing product is that due to iMAR's novel In-Motion alignment method, a dual antenna heading solution is not required (and hence not used) for robust heading initialization and the pilot is not required to wait for the alignment of the INS to complete before taxiing or takeoff.

Figure 18 shows the estimated accuracy of position (NED), velocity (NED) and attitude (roll, pitch, heading). Take into mind, that all the presented results of the iNAT-M200 system had been acquired and provided in real-time on the race aircraft, without any post-processing. No air data information or magnetic heading information had been used and only a single GNSS antenna had been applied on the aircraft (this makes the implementation on the aircraft much easier due to minimum cabling). GPS and GLONASS had been taken with L1L2 and standard WAAS/ EGNOS corrections via satellite.

On request, the system can be upgraded at site up to RTK and GALILEO capability to provide sub-decimeter level accuracy where needed.

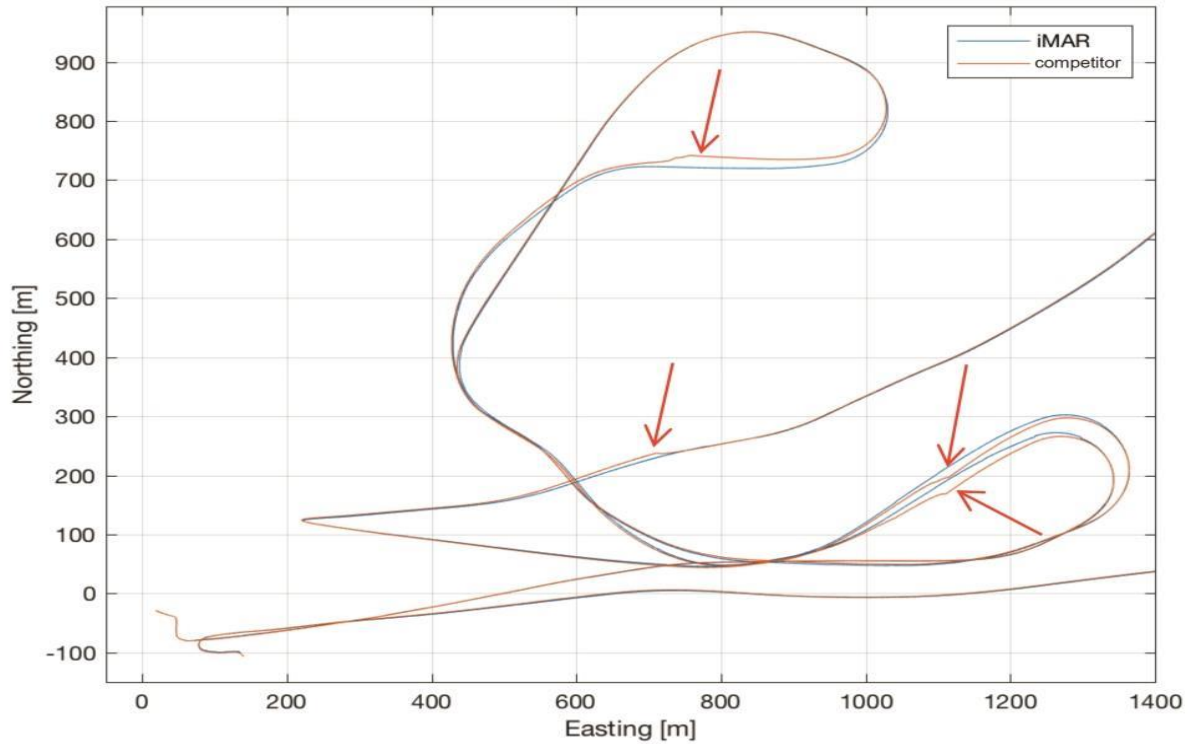

Figure 17: Comparison of Trajectory – iMAR Navigation vs. competitor's solution on the same aircraft (Ascot)

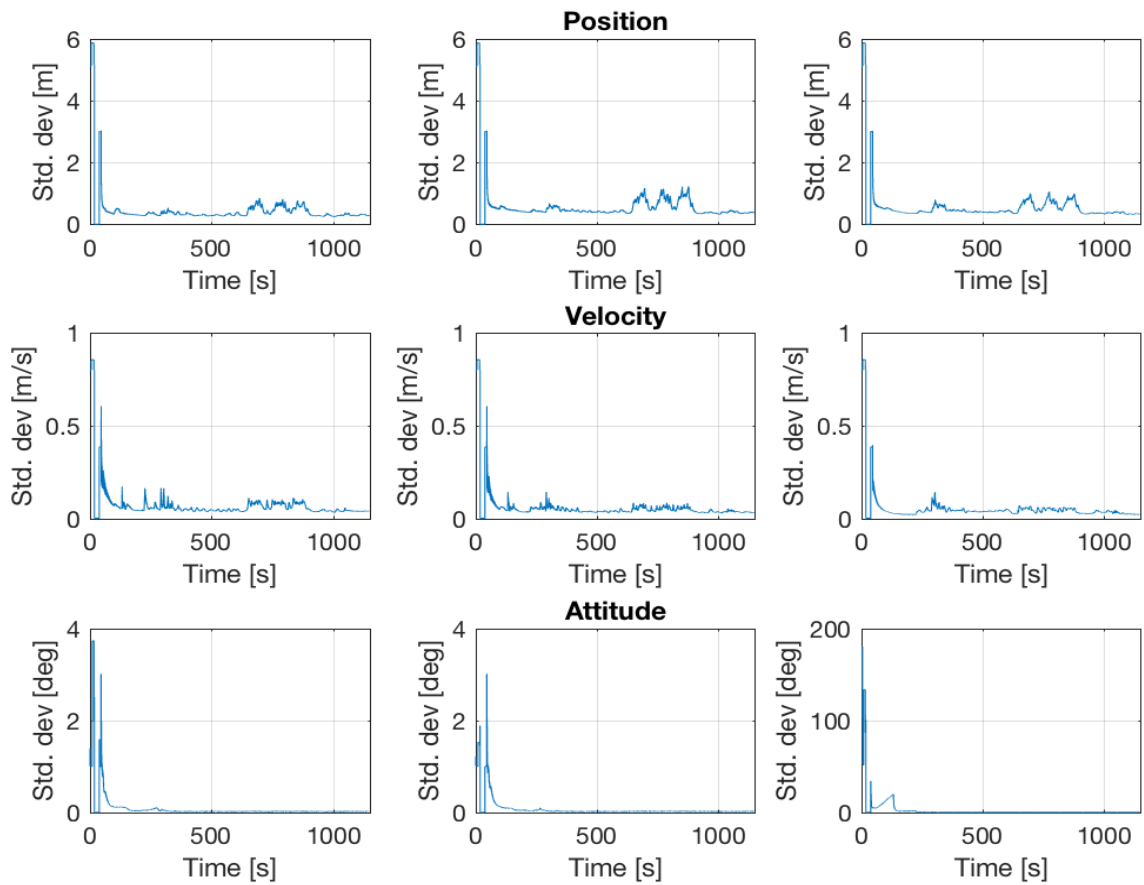

Figure 18: Estimated deviations of navigation solution

## 7 AIRBORNE GRAVIMETRY WITH iNAT-RQH

iNAT inertial measurement systems have been deployed in a very wide range of applications. One particularly demanding type of applications requiring highest classes of inertial sensor performance are airborne gravimetric measurements using the inertial sensors from the INS without need to use specialized gravimetric equipment. iMAR and the Columbia University have recently completed first test flights for gravimetric measurements with an iNAT-RQH in a wide-bodied aircraft.

Online results from iMAR's Kalman-filter based data fusion of GNSS and inertial data showed static alignment errors of less than 0.03 deg in heading and a navigation performance of significantly better than 0.2 nm/h. Online results are depicted in figures **Figure 19** and **Figure 20**. The flight had been performed in the USA in early September 2016, the plots of position and velocity are coordinated in NED and attitude in roll / pitch / yaw.

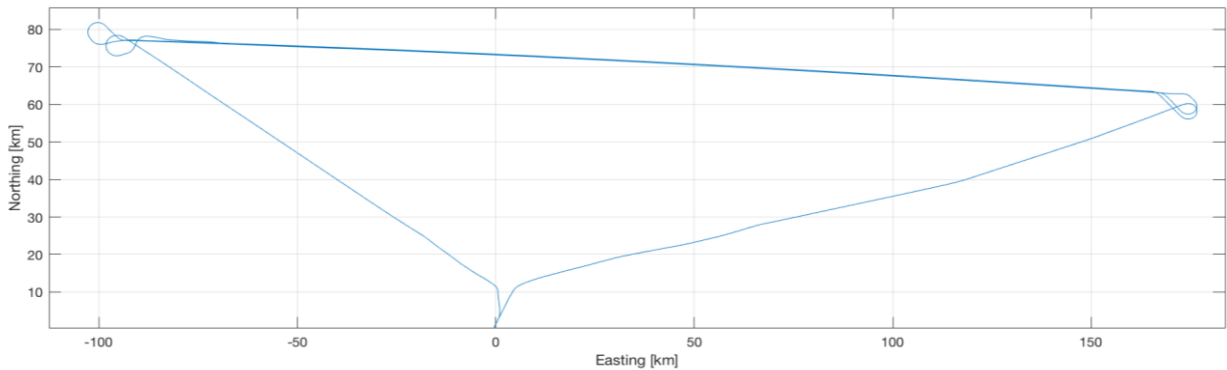

Figure 19: Trajectory profile of an airborne gravimetry test flight

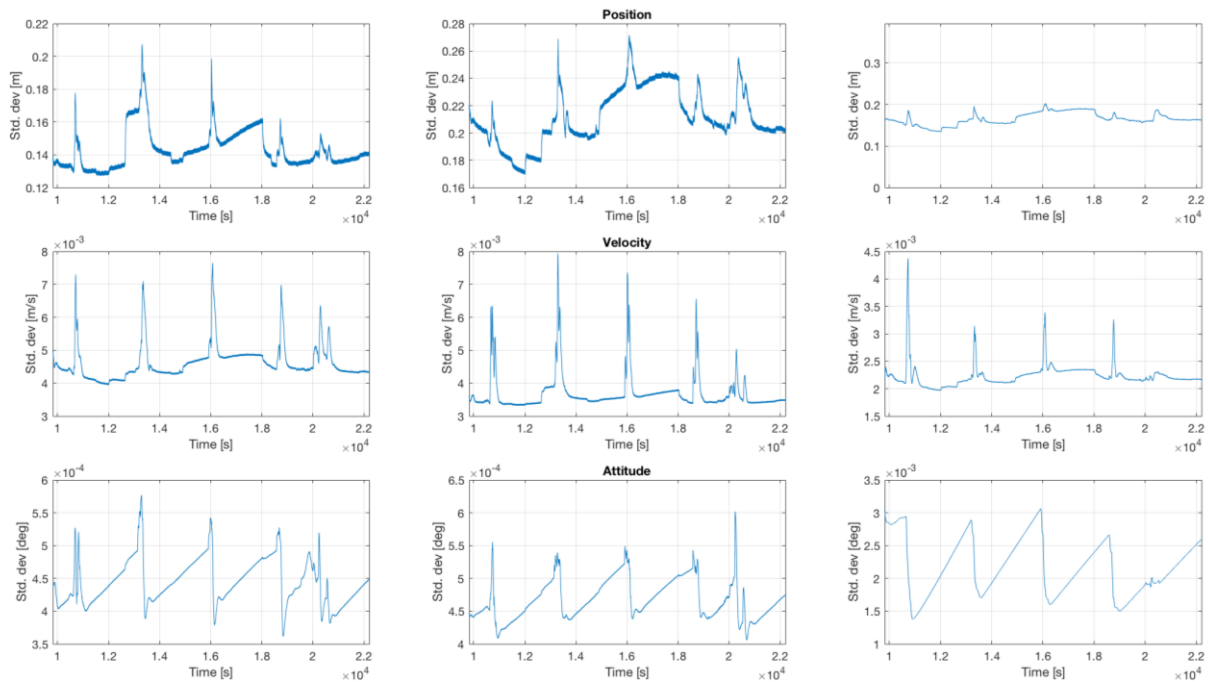

Figure 20: Standard deviations of navigation state during the test flight

The flight shown in the plots had been performed over about 12'000 sec, i.e. 3.3 hours. Due to the high performance of the used inertial sensors (ring laser gyroscopes and closed-loop quartz pendulous accelerometers) inside the iNAT-RQH-4001, very low errors in attitude ( $< 0.0006$  deg in roll/pitch,  $< 0.003$  deg in heading) and velocity ( $< 8$  mm/s) are achievable under sufficient dynamic motion with GNSS coverage, even without resorting to post-processing and without RTK aiding.

These results make the iNAT-RQH and iNAT-RQT systems also very attractive for advanced applications in laser scanning (LIDAR), photogrammetric surveying or SAR (synthetic aperture radar).



Columbia University extensively uses the online-recorded time-stamped raw inertial and GNSS data to post-process the data together with external GNSS reference station data as well as non-causal forward-backward processing to obtain gravity measurements reaching an accuracy of better than  $2 \mu\text{g}$  (i.e. 2 mGal), which compares very well with classical gravimetric instruments but for a fraction of the price.

## 8 CONCLUSION

With iNAT, iMAR has introduced a family of inertial measurement systems serving applications demanding the complete range of inertial sensor performance. All these systems feature a common hardware and software architecture, making iNAT the system of choice for system integrators in need of different device classes. The implementation of special customer requirements is easy thanks to the modular architecture in both hardware and software. All these systems feature low power consumption and are amongst the most compact devices in their respective performance classes.

In this paper, two different kinds of applications where the iNAT systems play a key role have been demonstrated. In both applications, iNAT systems enable both fast and cost-effective accomplishment of the application objective without standing in the way.

The report showed the challenging task to install a MEMS based INS on an aerobatic airplane and to perform excellent results on such application. The race plane has to fulfil extreme dynamics conditions with up to more than 10 g acceleration and 400 deg/s angular rate. This leads to high requirements regarding the inertial sensor bias stability, scale factor accuracy and time stamping to perform a most accurate signal processing inside the INS in real-time.

To be able to handle also the significant GNSS outages with high accuracy, the results of iMAR's powerful INS/GNSS data fusion containing a 42 state model, combined with iMAR's highly sophisticated and robust inertial sensors hardware, had been discussed. The performance achieved through this allowed Matthias Dolderer's Race Tacticians to take flight dynamics and trajectory analysis to new levels, which played a significant role in winning the World Champion title of the Red Bull Air Race in October 2016.

These methods are the same as to be used during the training of fighter pilots as well as for the control of highly dynamic UAV. Therefore the paper has shown that the presented system setup (INS/GNSS as well as optional airdata and magnetometer sensors from iMAR Navigation, data management and bus system from Stock Flight Systems) is very well suitable to be used as flight reference during pilot's education and training.

The results of the same data processing for high performance trajectory and geodetic surveying applications had been shown too.

## 9 ACKNOWLEDEMENT

The authors would like to thank Mr. Matthias Dolderer (MD21) and the Columbia University New York for the provision of the recorded data and the permission to publish results obtained from the flight campaigns.