

# iIPSC-TR: Tracker Range Control with Clusters of up to 4 on- or off-shore mounted Pedestals

## Features

- Control of up to 4 Azimuth/Elevation operated pedestals
- Each pedestal locally supported by
  - Stabilization & Control Unit (iSCU),
  - high speed video tracker (iOET<sup>2</sup>),
  - joystick control (iJP),
  - nominal trajectory information,
  - remote control capability
  - blind pointing capability
- Off-shore trackers supported by high performance Inertial Navigation System and GPS (for shipborne installation) for motion compensation
- Real-time processing and post-processing supported
- Operational support of mobile and static tracker installation: a high performance INS/GPS system of type iNAV-RQH can be applied in the base of the tracker to stabilize the payload on naval vessels or trucks

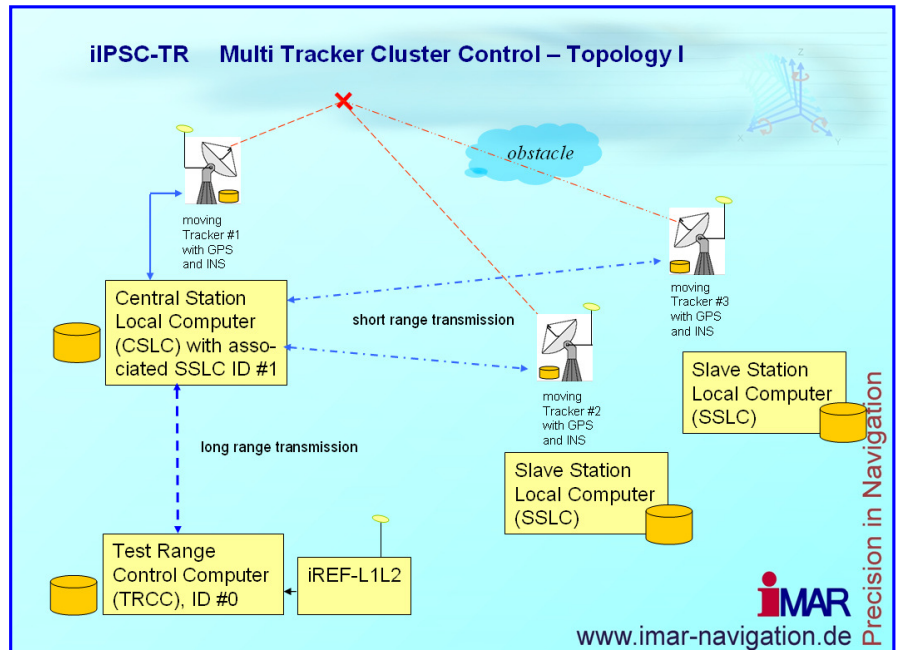

## Description

The iIPSC-TR is a complete tracker range installation to build up or to expand existing tracker ranges for tracking moving targets in the air or in the sea. Each tracker cluster consists of up to 4 Tracker Slave Stations (e.g. of type iIPSC-GP40 or iIPSC-MSG; selection depends on payload and environmental conditions), where each tracker is equipped with a video tracker (iOET<sup>2</sup>), motion control (iSCU), joystick panel (iJP), data recording and uninterrupted power supply (UPS). Up to 4 Slave Stations are served by one Central Station, which performs the triangulation computation, based on all data receiving from the Slave Stations. The Central Station provides the obtained trajectory information back to the Slave Stations to allow best tracking performance even if the target is covered temporarily by any obstacle. The Central Station also reports to the Test Range Central Computer (TRCC). In an alternative topology, each Slave Station (SSLC) can report also directly to the TRCC.

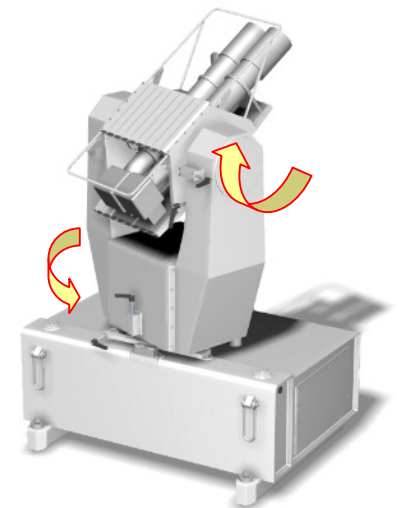

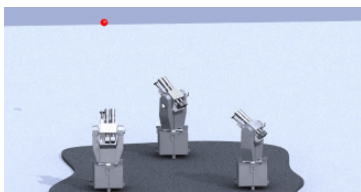
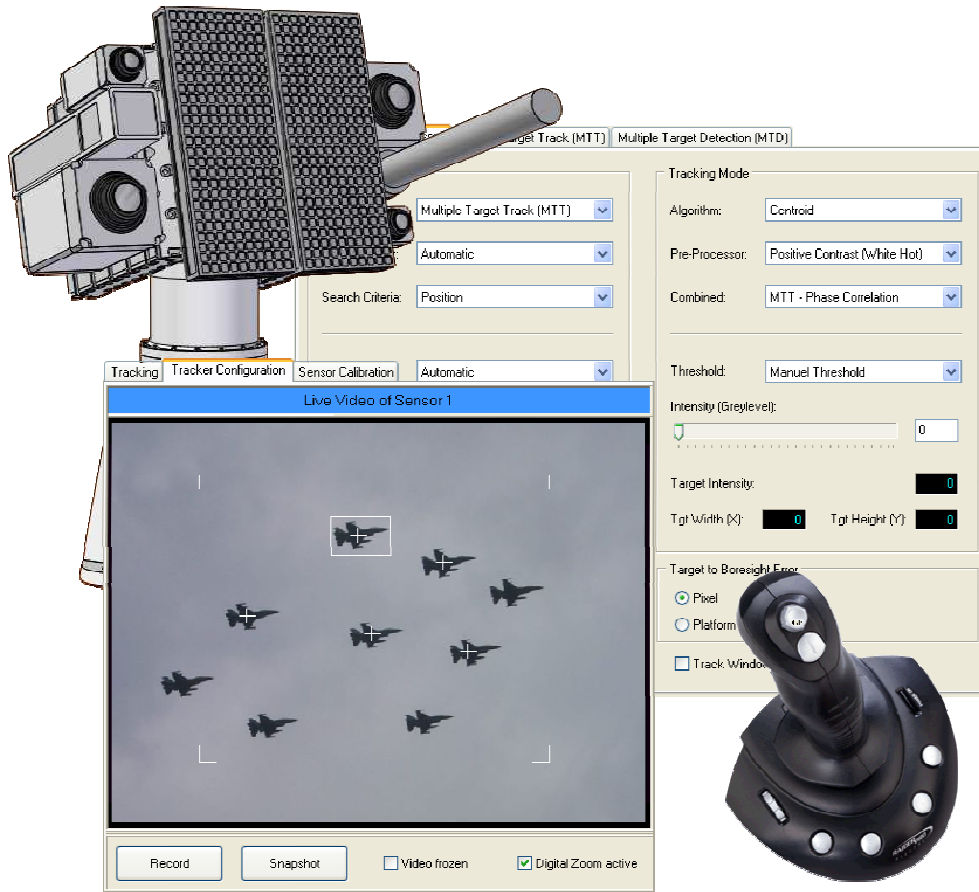

**Figures:**  
Video Tracker Interface (figure above) and principle of Target Tracking (small size figure left); ergonomic



Joystick Panel (JP) as operator control interface with full access to target video tracking (TVT) and motion control by joystick and external trajectory command (large size figure right) and the integrated ring laser gyro based inertial navigation system iNAV-RQH for enhanced off-shore platform stabilization and geo-referencing (figure left).



Pictures right up: off-shore and on-shore installations (implementation at Rafael Weapon Test & Eval. Center [WTEC at Shdema and Haifa], Israel)

**Contact**

iMAR GmbH, Systems for Inertial Navigation, Stabilization and Control  
 Im Reihersbruch 3 Tel: +49-6894-9657-0  
 D-66386 St. Ingbert Fax: +49-6894-9657-22  
 Germany eMail: [sales@imar-navigation.de](mailto:sales@imar-navigation.de)  
 Internet: [www.imar.de](http://www.imar.de)