

## Two Axes Gimballed Platform Series iIPSC-GP40

### Features

- Two-axes central payload platform: azimuth and elevation axes for LOS (line-of-sight) control
- Adaptable to different and multiple sensors due to customized mounting tray (option); balanced payload up to 40 kg
- Direct torque drives for highest resolution, negligible hysteresis and superior dynamics
- Made for mobile and static installation: a high performance INS/GPS system of type iNAV-RQH can be applied to stabilize the payload on naval vessels or trucks and for geo-referencing
- Available Control Features: iSCU Stabilization and Control Unit incl. iOET<sup>2</sup> Video Target Tracker, Image Fusion, iJP Joystick Panel, INS/GPS control and blind pointing
- Designed to operate in harsh environment and under naval and desert conditions

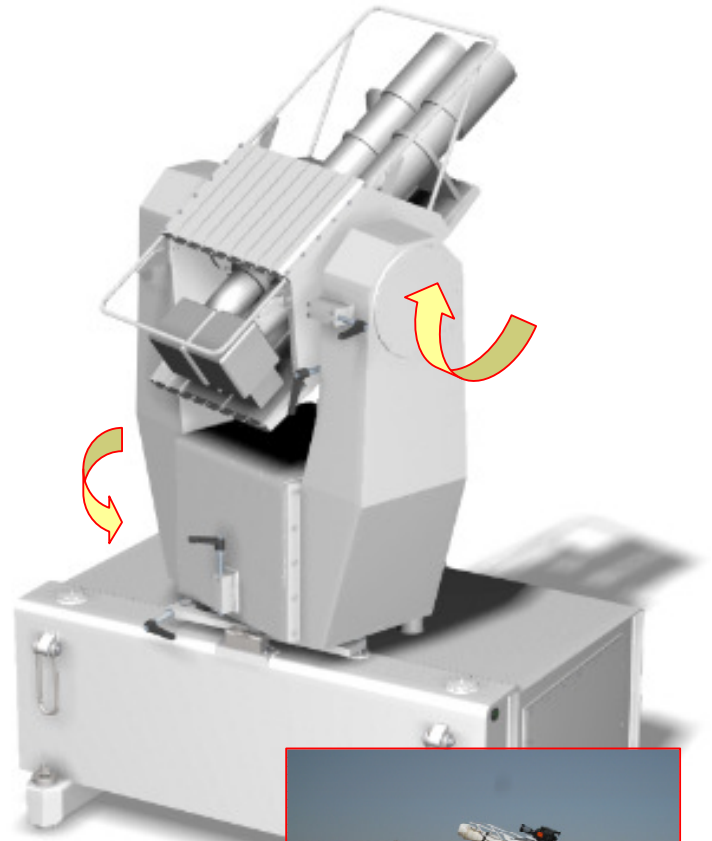

**iIPSC-GP40**



### Description

Direct drive brushless servo motors combined with direct drive high resolution encoders are ensuring the precise and smooth tracking of the iIPSC-GP40. All axes are sealed. The selected materials are corrosion resistant and surface treated to withstand harsh land based or shipboard environmental conditions. The basic instrument can be adapted to specific applications by the addition of optional equipment or features. iMAR GmbH, located in Germany, is manufacturer and system integrator of the iIPSC-GP40.

### Options

- The central payload platform can be replaced with a roll axis assembly enabling 3 DOF stabilization
- iOET<sup>2</sup> Opto Electronic Target Tracking for Auto Tracking, (with multi target capability and fast 50 meas./second); video blending available
- Dynamic Inertial stabilization with integrated INS/GPS positioning
- Spring isolated base plate to filter high frequency disturbance from the instrument.
- Separate shelter with operator console and integrated video recorders, UPS (uninterrupted power supply), joystick panel etc.

## Specification Summary

### General Configuration

Payload:	customer specific or standard sensors (see separate datasheet "iIPSC Payload Selection")
Payload weight, nominal:	40 kg on centered platform
Payload Signals:	Inner lower size of mounting plate: 430 x 230 x 780 mm Slip rings for payload data available (up to 7 x video, power, discrets)
Platform Total Size:	Power Consumption: up to 4'000 W, 230 VAC
Platform Weight:	approx. 1'100 x 1'300 x 1'800 mm approx. 350 kg

### Performance

	<b>Azimuth</b>	<b>Elevation</b>
Angular freedom (deg) Position	continuous	-30 to +185 (or tbd)
<ul style="list-style-type: none"> <li>• encoder resolution</li> <li>• resolution shaft</li> <li>• repeatability</li> </ul>	better 20 bit	better 20 bit
Rate (deg/sec)	1 arcsec	1 arcsec
Acceleration (deg/sec <sup>2</sup> )	±1.2 arcsec	±1.2 arcsec
Torque cont./peak (Nm)	> ±100	> ±100
Wobble (arcsec)	> ±100	> ±100
Perpendicularity (arcsec)	80/150	40/50
	<±2	<±6
	better than ±20	

### Environment Gyro Stabilisation (option)

Operating Temperature	-10 °C to +50 °C
Stabilization Performance	iNAV-RQH: < 0.2 mrad abs roll/pitch stabil. < 1 mrad abs heading stabi. < 50 µrad relative stabilization
	iVRU-FQ-E: < 0.25 mrad relative stabilization
	iOET <sup>2</sup> : 50 Hz, video target tracking, video fusion
Image Tracker Command	Stabilization Feedback via CAN or RS232/422 or Ethernet or/and joystick (see iMAR's iSCU interface)

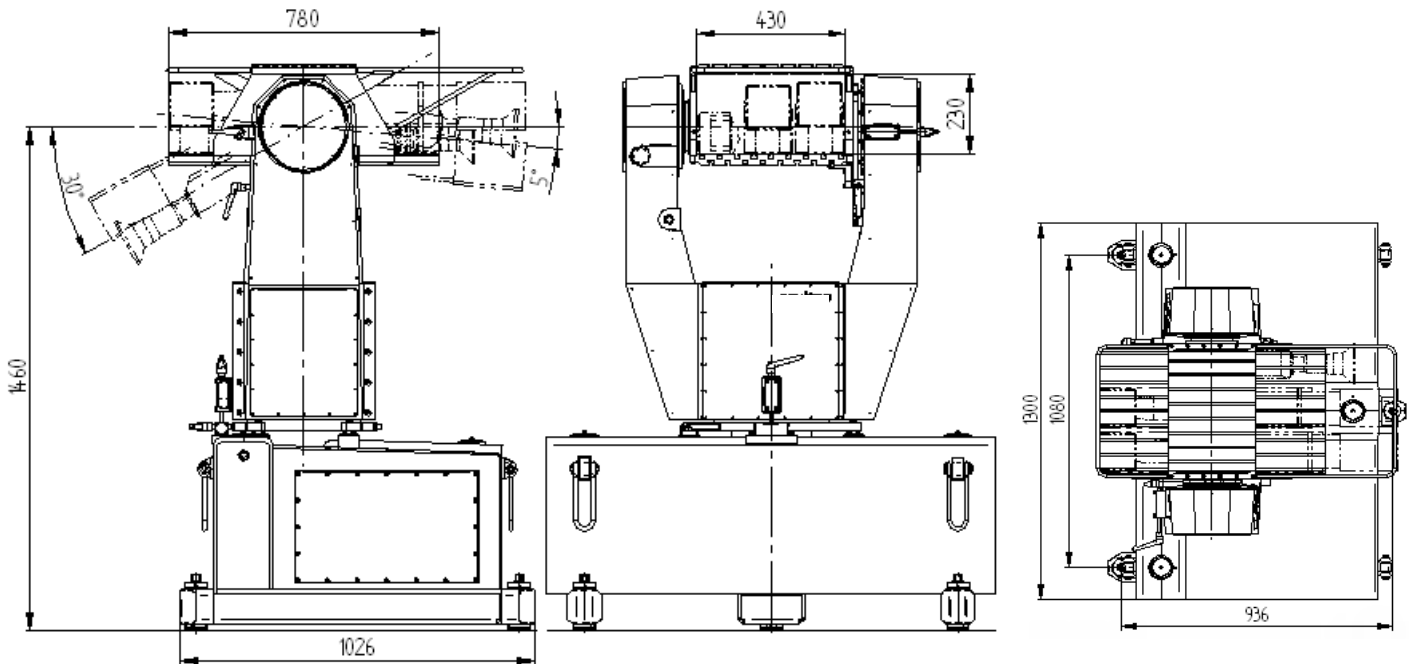

### Contact

iMAR GmbH, Systems for Inertial Navigation, Stabilization and Control  
Im Reihersbruch 3  
D-66386 St. Ingbert  
Germany

Tel: +49-6894-9657-0  
Fax: +49-6894-9657-22  
eMail: [sales@imar-navigation.de](mailto:sales@imar-navigation.de)  
Internet: [www.imar.de](http://www.imar.de)